

# Antares dryer ATT 025-340

with Tandem Technology



## Short Description

**Antares dryer with Tandem Technology** – an innovative family of dryers for compressed air from 2.5 to 34m<sup>3</sup>/min manufactured by Parker HZD (Hiross Zander Division). “Tandem Technology” effectively combines two well known classic drying techniques, working in harmony with one another, to form an optimised and unique compressed air treatment package - Refrigeration Technology/Adsorption Technology. This unique combination enables high-quality compressed air to be provided to the end-user at low energy consumption levels when compared to more traditional adsorption dryers.

**Antares Tandem Technology** constantly achieves a dew point of -40 °C as standard. To reach such levels of compressed air purity, patented product features and mode of operation contribute to extremely low purge-air requirements. Without the need to alter any of the components in the dryer, **AT-Technology** is able to supply a wide range of compressed air dew points, achieved by simply setting the desired value on the control panel. Dew points above zero, typical of the performance of a refrigeration dryer and dew points below zero (down to -70 °C), which are in the realms of adsorption technology, are easily achievable in an efficient and economical manner.



Untreated, humid compressed air is initially confronted by a pre-filter protecting a traditional, but modified and patented refrigeration circuit, where the majority of the water vapour is effectively removed from the incoming air. The second stage consists of a highly-compact desiccant drying stage, protected before and after by high-performance oil/water-aerosol and particle removal filters, which serves to further reduce the moisture content of the air to a standard dew point of -40 °C. Finally, clean, dry compressed air exits via the patented air/air heat-exchanger to be re-heated and delivered to the air distribution system.

Tried and tested, patent-pending technology, exploiting both PSA (pressure swing adsorption) and TSA (tempera-

ture swing adsorption) brings together an effective and economical solution to meet the needs of the compressed air user. With the addition of a dew-point dependent switching feature for periods of intermittent load, incorporated into the electronic controller of every **ATT dryer**, initial investment costs are quickly amortised and lifetime costs minimised.

**ATT dryers** equipped with an optional by-pass are ideally suited to meet the demands of seasonal variation, calling for application flexibility to meet dew points requirements above zero in summer and below zero in winter. In such cases Antares Tandem Technology can be operated solely as a refrigeration-dryer or alternatively “in tandem” with the adsorption stage.

# Product Specification

## Antares dryer ATT 025-340 with Tandem Technology

The major advantage of Parker Hiross “Antares Tandem Technology” over and above that of other compressed air drying technologies is its contribution to energy-efficiency and overall running-cost reduction. Less overall power consumption, less purge-air consumption, constant and stable outlet-pressure dew points and reduced operating and maintenance costs are the major features of this product range.

---



### Key Applications:

- Food & Beverage
- Surface treatment
- Instrumentation and control
- Automotive
- Materials handling
- Pharmaceutical
- Chemical
- Material forming
- Petrochemical

### Key Benefits:

- Lower operating costs vs. traditional heatless and heat-regenerative adsorption dryers (lower purge-air requirement and lower heater consumption).
- Reduced maintenance costs due to less desiccant-fill with extended life time.
- Exemption from periodic vessel inspection.
- Constant dew point performance - no peaks above set-point.
- „Dial-a dew point feature“ for seasonal operation (By-pass Option)
- Additional energy savings at partial load – (Dew-point-Dependent-Switching).
- Compact overall dimensions – Small footprint - Space saving.

### Scope of supply:

- Antares Tandem Technology dryer – supplied ready for installation.
- Complete with ISO-12500 validated oil/water-aerosol and particulate GL pre-filters, located prior to the refrigeration circuit, and pre-and post the adsorption stage.
- Dew-point Dependant Switching – A standard feature on all models.
- Integral timed-drain on models ATT025-090 - integral capacitance-drain on models ATT140-340.

### Optional:

- By-pass for seasonal operation (Models ATT060-340).
- 7“ colour -Touch Screen Display (Models ATT140-340).

# Product Specification

## Antares dryer ATT 025-340 with Tandem Technology

### Ordering – and Performance data

Model	Order-No.	Airflow <sup>1</sup> Inlet - Outlet m <sup>3</sup> /min	Air Con- nections BSPP-F	Max Pressure bar <sub>e</sub>	Effec- tive Avg. absorbed power <sup>2</sup> kW	Purge Air equivalent absorbed- power <sup>3</sup> kW	Refrig- erationcircuit Pre-filter „Oil/Water & particulate	Desiccant Pre-filter „Oil/Water- aerosol & particulate“	Desiccant After-filter „Particu- late“
ATT 025	ATT025-A23015016TI	2.5 – 2.4	1"	16	0.94	0.42	GL9ZL	GL9XL	GL9ZL
ATT 040	ATT040-A23015016TI	4 – 3.9	1"	16	1.30	0.68	GL11ZL	GL11XL	GL11ZL
ATT 060	ATT060-A23015012TI	6 – 5.8	1 ½"	12	1.27	1.02	GL11ZL	GL11XL	GL11ZL
ATT 090	ATT090-A23015012TI	9 – 8.7	1 ½"	12	1.94	1.53	GL12ZL	GL12XL	GL12ZL
ATT 140	ATT140-A40035012EI	14 – 13.6	2"	12	2.01	2.37	GL14ZL	GL14XL	GL14ZL
ATT 260	ATT260-A40035012EI	26 – 25.2	2 ½"	12	4.02	4.41	GL19ZL	GL19XL	GL19ZL
ATT 340	ATT340-A40035012EI	34 – 32.9	2 ½"	12	5.17	5.76	GL19ZL	GL19XL	GL19ZL

<sup>1</sup> referring to 1 bara and 20 °C at compressor suction capacity. Subsequently compressed to 7 bar<sub>e</sub> at 35 °C inlet to the dryer, at 100 % relative humidity, 25 °C ambient, for -40 °C

pressure dew point. Outlet flow is the average net flow following subtraction of the average purge-air flow.

<sup>2</sup> calculated throughout the entire cycle period - includes total refrigeration-circuit and desiccant heater absorbed power

<sup>3</sup> purge-air flow throughout the entire cycle period, evaluated as an air compressor absorbed power at the rate of 5.5 kW/m<sup>3</sup>/min.

### Operating Range

Site Selection	Frost-free indoor installation in a non-hazardous environment
Ambient Temperature	5 to 50 °C
Compressed air inlet temperature	3 to 65 °C
Operating pressure	3 to 16 bar <sub>e</sub> - ATT025-40 3 to 12 bar <sub>e</sub> - ATT060-340
Medium	Compressed air and gaseous nitrogen

### Electrical connections

Mains Voltage	230V, 1-phase, 50Hz on ATT025-090; 400V, 3-phase, 50Hz on ATT140-340
Protection class	IP44

### Materials of construction

Filters	See product-specification regarding GL filter ref: ZL and XL
Heat Exchanger fridge section	Stainless Steel plate-heat exchanger on ATT025-040 All-in-one „T-Smart Pack“ Aluminium heat exchanger on ATT060-340
Refrigerant fluid	R134a in ATT025-040; R407C in ATT060-340
Pressure vessels	Aluminium for ATT025-40; Carbon Steel for ATT60-340
Valve blocks	ATT025-140: Brass valve, Aluminium blocks, ATT260-340: 3-way valve galvanised steel, ball AISI 304, plastic check valves
Filling of desiccant section	Water-resistant Silica Gel

# Product Specification

## Antares dryer ATT 025-340 with Tandem Technology

### Pressure vessel approvals

EU	Approval for fluid group 2 in accordance with the Pressure Equipment Directive 97/23/EC (Annex A)
----	---

### Quality assurance

Development/Manufacture	DIN EN ISO 9001, DIN EN ISO 14001
-------------------------	-----------------------------------

### Correction factors for ATT model selection

Inlet Temperature (°C)	30	35	40	45	50	55	60	65
Correction Factor	1.22	1	0.81	0.69	0.59	0.52	0.46	0.4

Working Pressure <sup>1</sup> (bar <sub>e</sub> )	4	5	6	7	8	9	10	11	12	13	14	15	16
Correction Factor	0.62	0.75	0.87	1	1.08	1.2	1.28	1.34	1.4	1.45	1.5	1.54	1.6

Ambient Temperature (°C)	20	25	30	35	40	45	50
Correction Factor ATT025-040	1.05	1	0.94	0.88	0.81	0.75	0.68
Correction Factor ATT060-340	1.06	1	0.95	0.90	0.83	0.77	0.72

<sup>1</sup> Model ATT25 - ATT40 = 16 bar max  
Model ATT60 - ATT340 = 12 bar max

### Example: air flow 500m<sup>3</sup>/h, operating pressure 8 bar<sub>e</sub>, 40 °C inlet T, 30 °C ambient T, at -40 °C pdp

- 1) Find the correction factor in the table above: 8 bar<sub>e</sub> = 1.08 ; 40 °C inlet = 0.81 ; 30 °C ambient = 0.95
- 2) Calculate the required capacity:  $1.08 \times 0.81 \times 0.95 = 0.83$ ;  $500/0.83 = 602 \text{ m}^3/\text{h}$ ;  $602 / 60 = 10 \text{ m}^3/\text{min}$
- 3) Select the model which corresponds to the calculated capacity. It is acceptable to overload a model by 10 %:
  - a. If the requested air flow is intended to be the inlet flow to the dryer, select model ATT090.  
This model can nominally treat 9.0m<sup>3</sup>/min inlet flow. (loading it with 10m<sup>3</sup>/min is acceptable (approx. 10 % more).
  - b. If the requested air flow is intended to be the treated air flow at the output of the dryer, than select a larger model ATT140.  
Model ATT090 can deliver 8.7m<sup>3</sup>/min at the output, so requiring 10m<sup>3</sup>/min would be almost 15 % more than its rated performance. In this case the next model must be selected.
- 4) If the requirement is for a different dew-point, the selection procedure does not alter. The required pressure dew-point does not affect the model selection. It impacts only on the total power used by the selected model.

# Product Specification

## Antares dryer ATT 025-340 with Tandem Technology

### Factor to calculate the power consumption of an ATT model at pressure dew-point values which deviate from -40 °C and/or at partial load

Pressure Dew Point (°C)	Refrig. only	+3	0	-10	-20	-40	-70
Correction Factor	0.39	0.88	0.89	0.90	0.92	1	1.31

Partial Load	25 %	50 %	75 %	100 %
Correction Factor	0.66	0.82	0.94	1
Correction Factor Refrigeration-circuit only <sup>1</sup>	0.52	0.76	0.90	1

<sup>1</sup> Only for ATT 140, 260, 340

#### Example: ATT140 working at -20 °C pdp and loaded with 50 % of its nominal capacity

- 1) Find the correction factor in the table above: -20 °C pdp = 0.92 ; 50 % load = 0.82
- 2) The total power at nominal conditions consumed by model ATT140 (see performance table) is: 2.01 + 2.37 = 4.38kW
- 3) Apply the correction factor. The total power consumed at the new conditions is: 4.38 x 0.92 x 0.82 = 3.30kW

#### Example: ATT140 with seasonal "By-pass Option" (Refrigeration-circuit only active), unit loaded at 50%

- 1) Find the correction factor in the table above: Refrigeration-circuit only = 0.39 ; 50 % load with refrigeration-circuit only = 0.76
- 2) Apply the correction factor to the total power consumed by an ATT140. The new value is: 4.38 x 0.39 x 0.76 = 1.3kW

### Air quality classes, in accordance with ISO 8573-1:2010

Particulate	Class 2
Humidity (gaseous)	From Class 4 to Class 1 (depending upon sizing and dew point setting)
Total oil contamination	Class 2

# Product Specification

## Antares dryer ATT 025-340 with Tandem Technology

### Dimensions in mm, weight in kg

Model	A - Width	B - Height	C - Dept	Weight
ATT 025	706	1064	1246	180
ATT 040	706	1064	1246	200
ATT 060	806	1214	1416	295
ATT 090	806	1214	1416	335
ATT 140	1007	1586	1345	490
ATT 260	1007	1720	2535	880
ATT 340	1007	1720	2535	950

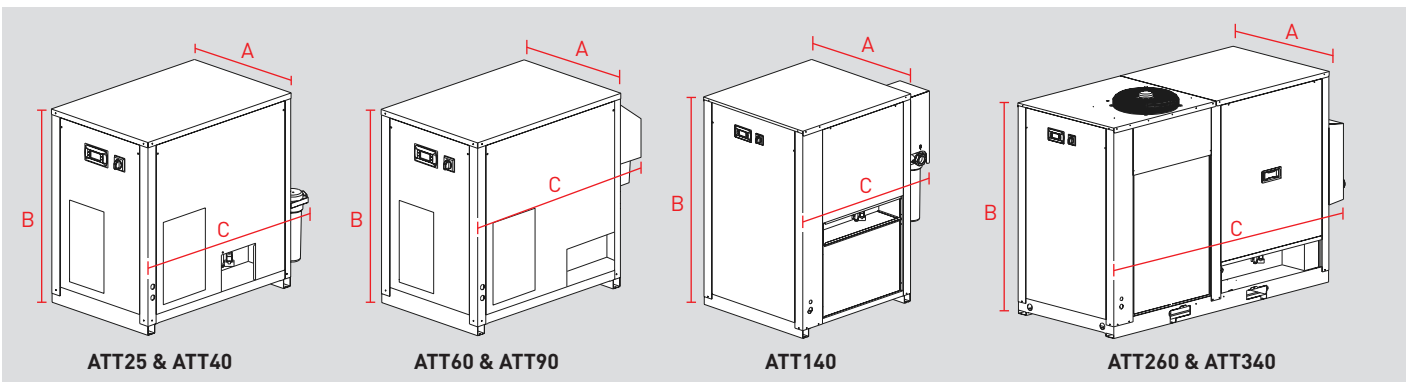

### Product key

Series	Inlet Flow rate * 10 (m <sup>3</sup> /min)	Condenser	Electrical Voltage, phase, frequency	Max Operating Pressure (bar <sub>e</sub> )	Drain Type	Optional by-pass winter/ summer	Optional Touch screen
ATT	025 to 040	A	230 1 50	16	TI or EX	-	-
ATT	060 to 090	A	230 1 50	12	TI or EX	TB	-
ATT	140 to 340	A	400 3 50	12	EI	TB	TS

### Examples

ATT	040	A	230150	16	TI		
ATT model for 4 m <sup>3</sup> /min inlet, air cooled, 230 V, 1-phase, 50Hz power supply, max 16bar <sub>e</sub> operating pressure, equipped with integral timed-drain							
ATT	040	A	230150	16	EX		
ATT model for 4 m <sup>3</sup> /min inlet, air cooled, 230 V, 1-phase, 50Hz power supply, max 16bar <sub>e</sub> , equipped with external electronic capacitive-drain							
ATT	260	A	400350	12	EI	TS	
ATT model for 26 m <sup>3</sup> /min inlet, air cooled, 400 V, 3-phase, 50Hz power supply, max 12bar <sub>e</sub> operating pressure, equipped with integral electronic capacitive-drain and 7" touch screen display							
ATT	140	A	400350	12	EI	TB	TS
ATT model for 14 m <sup>3</sup> /min inlet, air cooled, 400 V, 3-phase, 50Hz power supply, max 12bar <sub>e</sub> operating pressure, equipped with integral electronic capacitive-drain, seasonal "By-Pass" and 7" touch screen display							



# Parker's Motion & Control Technologies

At Parker, we're guided by a relentless drive to help our customers become more productive and achieve higher levels of profitability by engineering the best systems for their requirements. It means looking at customer applications from many angles to find new ways to create value. Whatever the motion and control technology need, Parker has the experience, breadth of product and global reach to consistently deliver. No company knows more about motion and control technology than Parker. For further info call 00800 27 27 5374



## Aerospace

### Key Markets

Aftermarket services  
Commercial transports  
Engines  
General & business aviation  
Helicopters  
Launch vehicles  
Military aircraft  
Missiles  
Power generation  
Regional transports  
Unmanned aerial vehicles

### Key Products

Control systems & actuation products  
Engine systems & components  
Fluid conveyance systems & components  
Fluid metering, delivery & atomization devices  
Fuel systems & components  
Fuel tank inerting systems  
Hydraulic systems & components  
Thermal management  
Wheels & brakes



## Climate Control

### Key Markets

Agriculture  
Air conditioning  
Construction Machinery  
Food & beverage  
Industrial machinery  
Life sciences  
Oil & gas  
Precision cooling  
Process  
Refrigeration  
Transportation

### Key Products

Accumulators  
Advanced actuators  
CO<sub>2</sub> controls  
Electronic controllers  
Filter driers  
Hand shut-off valves  
Heat exchangers  
Hose & fittings  
Pressure regulating valves  
Refrigerant distributors  
Safety relief valves  
Smart pumps  
Solenoid valves  
Thermostatic expansion valves



## Electromechanical

### Key Markets

Aerospace  
Factory automation  
Life science & medical  
Machine tools  
Packaging machinery  
Paper machinery  
Plastics machinery & converting  
Primary metals  
Semiconductor & electronics  
Textile  
Wire & cable

### Key Products

AC/DC drives & systems  
Electric actuators, gantry robots & slides  
Electrohydraulic actuation systems  
Electromechanical actuation systems  
Human machine interface  
Linear motors  
Stepper motors, servo motors, drives & controls  
Structural extrusions



## Filtration

### Key Markets

Aerospace  
Food & beverage  
Industrial plant & equipment  
Life sciences  
Marine  
Mobile equipment  
Oil & gas  
Power generation & renewable energy  
Process  
Transportation  
Water Purification

### Key Products

Analytical gas generators  
Compressed air filters & driers  
Engine air, coolant, fuel & oil filtration systems  
Fluid condition monitoring systems  
Hydraulic & lubrication filters  
Hydrogen, nitrogen & zero air generators  
Instrumentation filters  
Membrane & fiber filters  
Microfiltration  
Sterile air filtration  
Water desalination & purification filters & systems



## Fluid & Gas Handling

### Key Markets

Aerial lift  
Agriculture  
Bulk chemical handling  
Construction machinery  
Food & beverage  
Fuel & gas delivery  
Industrial machinery  
Life sciences  
Marine  
Mining  
Mobile  
Oil & gas  
Renewable energy  
Transportation

### Key Products

Check valves  
Connectors for low pressure fluid conveyance  
Deep sea umbilicals  
Diagnostic equipment  
Hose couplings  
Industrial hose  
Mooring systems & power cables  
PTFE hose & tubing  
Quick couplings  
Rubber & thermoplastic hose  
Tube fittings & adapters  
Tubing & plastic fittings



## Hydraulics

### Key Markets

Aerial lift  
Agriculture  
Alternative energy  
Construction machinery  
Forestry  
Industrial machinery  
Machine tools  
Marine  
Material handling  
Mining  
Oil & gas  
Power generation  
Refuse vehicles  
Renewable energy  
Truck hydraulics  
Turf equipment

### Key Products

Accumulators  
Cartridge valves  
Electrohydraulic actuators  
Human machine interfaces  
Hybrid drives  
Hydraulic cylinders  
Hydraulic motors & pumps  
Hydraulic systems  
Hydraulic valves & controls  
Hydrostatic steering  
Integrated hydraulic circuits  
Power take-offs  
Power units  
Rotary actuators  
Sensors



## Pneumatics

### Key Markets

Aerospace  
Conveyor & material handling  
Factory automation  
Life science & medical  
Machine tools  
Packaging machinery  
Transportation & automotive

### Key Products

Air preparation  
Brass fittings & valves  
Manifolds  
Pneumatic accessories  
Pneumatic actuators & grippers  
Pneumatic valves & controls  
Quick disconnects  
Rotary actuators  
Rubber & thermoplastic hose & couplings  
Structural extrusions  
Thermoplastic tubing & fittings  
Vacuum generators, cups & sensors



## Process Control

### Key Markets

Alternative fuels  
Biopharmaceuticals  
Chemical & refining  
Food & beverage  
Marine & shipbuilding  
Medical & dental  
Microelectronics  
Nuclear Power  
Offshore oil exploration  
Oil & gas  
Pharmaceuticals  
Power generation  
Pulp & paper  
Steel  
Water/wastewater

### Key Products

Analytical Instruments  
Analytical sample conditioning products & systems  
Chemical injection fittings & valves  
Fluoropolymer chemical delivery fittings, valves & pumps  
High purity gas delivery fittings, valves, regulators & digital flow controllers  
Industrial mass flow meters/controllers  
Permanent no-weld tube fittings  
Precision industrial regulators & flow controllers  
Process control double block & bleeds  
Process control fittings, valves, regulators & manifold valves



## Sealing & Shielding

### Key Markets

Aerospace  
Chemical processing  
Consumer  
Fluid power  
General Industrial  
Information technology  
Life sciences  
Microelectronics  
Military  
Oil & gas  
Power generation  
Renewable energy  
Telecommunications  
Transportation

### Key Products

Dynamic seals  
Elastomeric o-rings  
Electro-medical instrument design & assembly  
EMI shielding  
Extruded & precision-cut, fabricated elastomeric seals  
High temperature metal seals  
Homogeneous & inserted elastomeric shapes  
Medical device fabrication & assembly  
Metal & plastic retained composite seals  
Shielded optical windows  
Silicone tubing & extrusions  
Thermal management  
Vibration dampening

ENGINEERING YOUR SUCCESS.

# Parker Worldwide

## Europe, Middle East, Africa

**AE – United Arab Emirates,** Dubai  
Tel: +971 4 8127100  
parker.me@parker.com

**AT – Austria,** Wiener Neustadt  
Tel: +43 (0)2622 23501-0  
parker.austria@parker.com

**AT – Eastern Europe,** Wiener Neustadt  
Tel: +43 (0)2622 23501 900  
parker.easteurope@parker.com

**AZ – Azerbaijan,** Baku  
Tel: +994 50 2233 458  
parker.azerbaijan@parker.com

**BE/LU – Belgium,** Nivelles  
Tel: +32 (0)67 280 900  
parker.belgium@parker.com

**BY – Belarus,** Minsk  
Tel: +375 17 209 9399  
parker.belarus@parker.com

**CH – Switzerland,** Etoy  
Tel: +41 (0)21 821 87 00  
parker.switzerland@parker.com

**CZ – Czech Republic,** Klecany  
Tel: +420 284 083 111  
parker.czechrepublic@parker.com

**DE – Germany,** Kaarst  
Tel: +49 (0)2131 4016 0  
parker.germany@parker.com

**DK – Denmark,** Ballerup  
Tel: +45 43 56 04 00  
parker.denmark@parker.com

**ES – Spain,** Madrid  
Tel: +34 902 330 001  
parker.spain@parker.com

**FI – Finland,** Vantaa  
Tel: +358 (0)20 753 2500  
parker.finland@parker.com

**FR – France,** Contamine s/Arve  
Tel: +33 (0)4 50 25 80 25  
parker.france@parker.com

**GR – Greece,** Athens  
Tel: +30 210 933 6450  
parker.greece@parker.com

**HU – Hungary,** Budapest  
Tel: +36 1 220 4155  
parker.hungary@parker.com

**IE – Ireland,** Dublin  
Tel: +353 (0)1 466 6370  
parker.ireland@parker.com

**IT – Italy,** Corsico (MI)  
Tel: +39 02 45 19 21  
parker.italy@parker.com

**KZ – Kazakhstan,** Almaty  
Tel: +7 7272 505 800  
parker.easteurope@parker.com

**NL – The Netherlands,** Oldenzaal  
Tel: +31 (0)541 585 000  
parker.nl@parker.com

**NO – Norway,** Asker  
Tel: +47 66 75 34 00  
parker.norway@parker.com

**PL – Poland,** Warsaw  
Tel: +48 (0)22 573 24 00  
parker.poland@parker.com

**PT – Portugal,** Leca da Palmeira  
Tel: +351 22 999 7360  
parker.portugal@parker.com

**RO – Romania,** Bucharest  
Tel: +40 21 252 1382  
parker.romania@parker.com

**RU – Russia,** Moscow  
Tel: +7 495 645-2156  
parker.russia@parker.com

**SE – Sweden,** Spånga  
Tel: +46 (0)8 59 79 50 00  
parker.sweden@parker.com

**SK – Slovakia,** Banská Bystrica  
Tel: +421 484 162 252  
parker.slovakia@parker.com

**SL – Slovenia,** Novo Mesto  
Tel: +386 7 337 6650  
parker.slovenia@parker.com

**TR – Turkey,** Istanbul  
Tel: +90 216 4997081  
parker.turkey@parker.com

**UA – Ukraine,** Kiev  
Tel: +380 44 494 2731  
parker.ukraine@parker.com

**UK – United Kingdom,** Warwick  
Tel: +44 (0)1926 317 878  
parker.uk@parker.com

**ZA – South Africa,** Kempton Park  
Tel: +27 (0)11 961 0700  
parker.southafrica@parker.com

## North America

**CA – Canada,** Milton, Ontario  
Tel: +1 905 693 3000

**US – USA,** Cleveland  
Tel: +1 216 896 3000

## Asia Pacific

**AU – Australia,** Castle Hill  
Tel: +61 (0)2-9634 7777

**CN – China,** Shanghai  
Tel: +86 21 2899 5000

**HK – Hong Kong**  
Tel: +852 2428 8008

**IN – India,** Mumbai  
Tel: +91 22 6513 7081-85

**JP – Japan,** Tokyo  
Tel: +81 (0)3 6408 3901

**KR – South Korea,** Seoul  
Tel: +82 2 559 0400

**MY – Malaysia,** Shah Alam  
Tel: +60 3 7849 0800

**NZ – New Zealand,** Mt Wellington  
Tel: +64 9 574 1744

**SG – Singapore**  
Tel: +65 6887 6300

**TH – Thailand,** Bangkok  
Tel: +662 186 7000-99

**TW – Taiwan,** Taipei  
Tel: +886 2 2298 8987

## South America

**AR – Argentina,** Buenos Aires  
Tel: +54 3327 44 4129

**BR – Brazil,** Sao Jose dos Campos  
Tel: +55 800 727 5374

**CL – Chile,** Santiago  
Tel: +56 2 623 1216

**MX – Mexico,** Apodaca  
Tel: +52 81 8156 6000